

# Carey Road @ Harriet Road

Wednesday, April 03, 2019



The data presented here is for information purposes only and should not be considered authoritative for construction, geotechnical, engineering, navigational, legal, or other site-specific uses. The information shared is owned by the Transportation Division of the Engineering Department at the District of Saanich. Accuracy is not guaranteed.

**Major Route:** Carey Road  
**Minor Route:** Harriet Road  
**Municipality:** Saanich  
**Filename:** Carey Rd @ Harriet Rd-Apr 3, 2019.xlsx  
**Location #:** TIN001139  
**Count ID:** 2019004  
**Date:** April 3, 2019  
**Day-of-week:** Wednesday

**East/West Route:** Harriet Road  
**Intersection Type:** 3-leg west approach  
**Signalized?:** No  
**Weather:** Overcast and dry

**Vehicle Classifications:** Vehicles and Peds  
 Bikes

**This data is for Vehicles and Peds**

| Shift        | Start       | End          | Duration    |
|--------------|-------------|--------------|-------------|
| AM           | 7:30        | 9:30         | 2.00        |
| MD           |             |              |             |
| PM           | 15:30       | 18:30        | 3.00        |
| <b>Total</b> | <b>7:30</b> | <b>18:30</b> | <b>5.00</b> |

**Notes:** 24-hour clock used for reporting (15-minute increments)  
 North Approach - southbound vehicles approaching intersection from the north  
 15x4 - 15 min volume (from maximum 15 minute period of movement/approach in peak hour period [\*]) x 4  
 Pedestrians - N indicates pedestrians crossing north approach (east/west)

**Comments:**

Survey Data  
Vehicles and Peds

Carey Road @ Harriet Road  
Wednesday, April 3, 2019

| Time<br>Period<br>Begins | Carey Rd       |      |       |       | Carey Rd       |      |       |       | Harriet Rd    |      |       |       | EAST Approach |      |       |       | Total Volume |      | Ped<br>Obs | Crosswalks |   |    |   |
|--------------------------|----------------|------|-------|-------|----------------|------|-------|-------|---------------|------|-------|-------|---------------|------|-------|-------|--------------|------|------------|------------|---|----|---|
|                          | NORTH Approach |      |       |       | SOUTH Approach |      |       |       | WEST Approach |      |       |       | EAST Approach |      |       |       | 15-min       | Hour |            | N          | S | W  | E |
|                          | Left           | Thru | Right | Total | Left           | Thru | Right | Total | Left          | Thru | Right | Total | Left          | Thru | Right | Total |              |      |            |            |   |    |   |
| 7:30                     |                | 96   | 5     | 101   | 4              | 28   |       | 32    | 3             |      | 6     | 9     |               |      |       |       | 142          |      |            | 1          | 0 | 5  |   |
| 7:45                     |                | 122  | 8     | 130   | 2              | 43   |       | 45    | 1             |      | 4     | 5     |               |      |       |       | 180          | *    |            | 0          | 0 | 0  |   |
| 8:00                     |                | 130  | 7     | 137   | 0              | 41   |       | 41    | 3             |      | 4     | 7     |               |      |       |       | 185          | +    |            | 1          | 0 | 2  |   |
| 8:15                     |                | 104  | 7     | 111   | 1              | 58   |       | 59    | 8             |      | 6     | 14    |               |      |       |       | 184          | 691  | *          | 1          | 0 | 0  |   |
| 8:30                     |                | 103  | 12    | 115   | 2              | 37   |       | 39    | 4             |      | 4     | 8     |               |      |       |       | 162          | 711  | *          | 0          | 0 | 1  |   |
| 8:45                     |                | 120  | 5     | 125   | 2              | 40   |       | 42    | 3             |      | 5     | 8     |               |      |       |       | 175          | 706  |            | 1          | 1 | 3  |   |
| 9:00                     |                | 113  | 7     | 120   | 2              | 51   |       | 53    | 3             |      | 7     | 10    |               |      |       |       | 183          | 704  |            | 3          | 1 | 5  |   |
| 9:15                     |                | 80   | 5     | 85    | 0              | 45   |       | 45    | 4             |      | 6     | 10    |               |      |       |       | 140          | 660  |            | 0          | 0 | 4  |   |
| n/a                      |                |      |       |       |                |      |       |       |               |      |       |       |               |      |       |       |              |      |            |            |   |    |   |
| n/a                      |                |      |       |       |                |      |       |       |               |      |       |       |               |      |       |       |              |      |            |            |   |    |   |
| n/a                      |                |      |       |       |                |      |       |       |               |      |       |       |               |      |       |       |              |      |            |            |   |    |   |
| n/a                      |                |      |       |       |                |      |       |       |               |      |       |       |               |      |       |       |              |      |            |            |   |    |   |
| n/a                      |                |      |       |       |                |      |       |       |               |      |       |       |               |      |       |       |              |      |            |            |   |    |   |
| n/a                      |                |      |       |       |                |      |       |       |               |      |       |       |               |      |       |       |              |      |            |            |   |    |   |
| n/a                      |                |      |       |       |                |      |       |       |               |      |       |       |               |      |       |       |              |      |            |            |   |    |   |
| n/a                      |                |      |       |       |                |      |       |       |               |      |       |       |               |      |       |       |              |      |            |            |   |    |   |
| n/a                      |                |      |       |       |                |      |       |       |               |      |       |       |               |      |       |       |              |      |            |            |   |    |   |
| n/a                      |                |      |       |       |                |      |       |       |               |      |       |       |               |      |       |       |              |      |            |            |   |    |   |
| n/a                      |                |      |       |       |                |      |       |       |               |      |       |       |               |      |       |       |              |      |            |            |   |    |   |
| n/a                      |                |      |       |       |                |      |       |       |               |      |       |       |               |      |       |       |              |      |            |            |   |    |   |
| n/a                      |                |      |       |       |                |      |       |       |               |      |       |       |               |      |       |       |              |      |            |            |   |    |   |
| n/a                      |                |      |       |       |                |      |       |       |               |      |       |       |               |      |       |       |              |      |            |            |   |    |   |
| n/a                      |                |      |       |       |                |      |       |       |               |      |       |       |               |      |       |       |              |      |            |            |   |    |   |
| n/a                      |                |      |       |       |                |      |       |       |               |      |       |       |               |      |       |       |              |      |            |            |   |    |   |
| Total                    |                | 868  | 56    | 924   | 13             | 343  |       | 356   | 29            |      | 42    | 71    |               |      |       |       | 1351         |      |            | 7          | 2 | 20 |   |

|       |  |  |  |  |  |  |  |  |  |  |  |  |  |  |  |  |  |  |  |  |  |  |
|-------|--|--|--|--|--|--|--|--|--|--|--|--|--|--|--|--|--|--|--|--|--|--|
| n/a   |  |  |  |  |  |  |  |  |  |  |  |  |  |  |  |  |  |  |  |  |  |  |
| n/a   |  |  |  |  |  |  |  |  |  |  |  |  |  |  |  |  |  |  |  |  |  |  |
| n/a   |  |  |  |  |  |  |  |  |  |  |  |  |  |  |  |  |  |  |  |  |  |  |
| n/a   |  |  |  |  |  |  |  |  |  |  |  |  |  |  |  |  |  |  |  |  |  |  |
| n/a   |  |  |  |  |  |  |  |  |  |  |  |  |  |  |  |  |  |  |  |  |  |  |
| n/a   |  |  |  |  |  |  |  |  |  |  |  |  |  |  |  |  |  |  |  |  |  |  |
| n/a   |  |  |  |  |  |  |  |  |  |  |  |  |  |  |  |  |  |  |  |  |  |  |
| n/a   |  |  |  |  |  |  |  |  |  |  |  |  |  |  |  |  |  |  |  |  |  |  |
| n/a   |  |  |  |  |  |  |  |  |  |  |  |  |  |  |  |  |  |  |  |  |  |  |
| n/a   |  |  |  |  |  |  |  |  |  |  |  |  |  |  |  |  |  |  |  |  |  |  |
| n/a   |  |  |  |  |  |  |  |  |  |  |  |  |  |  |  |  |  |  |  |  |  |  |
| n/a   |  |  |  |  |  |  |  |  |  |  |  |  |  |  |  |  |  |  |  |  |  |  |
| n/a   |  |  |  |  |  |  |  |  |  |  |  |  |  |  |  |  |  |  |  |  |  |  |
| n/a   |  |  |  |  |  |  |  |  |  |  |  |  |  |  |  |  |  |  |  |  |  |  |
| n/a   |  |  |  |  |  |  |  |  |  |  |  |  |  |  |  |  |  |  |  |  |  |  |
| n/a   |  |  |  |  |  |  |  |  |  |  |  |  |  |  |  |  |  |  |  |  |  |  |
| n/a   |  |  |  |  |  |  |  |  |  |  |  |  |  |  |  |  |  |  |  |  |  |  |
| Total |  |  |  |  |  |  |  |  |  |  |  |  |  |  |  |  |  |  |  |  |  |  |

|       |  |     |    |     |    |      |  |      |    |  |    |     |  |  |  |  |      |      |   |   |   |    |
|-------|--|-----|----|-----|----|------|--|------|----|--|----|-----|--|--|--|--|------|------|---|---|---|----|
| 15:30 |  | 82  | 5  | 87  | 5  | 158  |  | 163  | 7  |  | 4  | 11  |  |  |  |  | 261  |      |   | 0 | 0 | 4  |
| 15:45 |  | 61  | 10 | 71  | 3  | 192  |  | 195  | 6  |  | 3  | 9   |  |  |  |  | 275  |      |   | 1 | 0 | 4  |
| 16:00 |  | 67  | 4  | 71  | 3  | 200  |  | 203  | 7  |  | 8  | 15  |  |  |  |  | 289  |      |   | 1 | 0 | 4  |
| 16:15 |  | 73  | 2  | 75  | 4  | 216  |  | 220  | 7  |  | 5  | 12  |  |  |  |  | 307  | 1132 | + | 2 | 0 | 4  |
| 16:30 |  | 64  | 4  | 68  | 3  | 205  |  | 208  | 4  |  | 1  | 5   |  |  |  |  | 281  | 1152 | * | 0 | 0 | 2  |
| 16:45 |  | 79  | 4  | 83  | 1  | 202  |  | 203  | 6  |  | 6  | 12  |  |  |  |  | 298  | 1175 | * | 0 | 2 | 7  |
| 17:00 |  | 65  | 4  | 69  | 0  | 215  |  | 215  | 8  |  | 7  | 15  |  |  |  |  | 299  | 1185 | * | 0 | 1 | 1  |
| 17:15 |  | 77  | 4  | 81  | 8  | 184  |  | 192  | 1  |  | 1  | 2   |  |  |  |  | 275  | 1153 |   | 0 | 0 | 5  |
| 17:30 |  | 70  | 3  | 73  | 3  | 164  |  | 167  | 2  |  | 5  | 7   |  |  |  |  | 247  | 1119 |   | 0 | 0 | 1  |
| 17:45 |  | 63  | 4  | 67  | 2  | 113  |  | 115  | 8  |  | 3  | 11  |  |  |  |  | 193  | 1014 |   | 1 | 2 | 5  |
| 18:00 |  | 60  | 0  | 60  | 3  | 136  |  | 139  | 2  |  | 4  | 6   |  |  |  |  | 205  | 920  |   | 0 | 0 | 5  |
| 18:15 |  | 38  | 3  | 41  | 3  | 96   |  | 99   | 2  |  | 1  | 3   |  |  |  |  | 143  | 788  |   | 1 | 0 | 1  |
| n/a   |  |     |    |     |    |      |  |      |    |  |    |     |  |  |  |  |      |      |   |   |   |    |
| n/a   |  |     |    |     |    |      |  |      |    |  |    |     |  |  |  |  |      |      |   |   |   |    |
| n/a   |  |     |    |     |    |      |  |      |    |  |    |     |  |  |  |  |      |      |   |   |   |    |
| n/a   |  |     |    |     |    |      |  |      |    |  |    |     |  |  |  |  |      |      |   |   |   |    |
| n/a   |  |     |    |     |    |      |  |      |    |  |    |     |  |  |  |  |      |      |   |   |   |    |
| n/a   |  |     |    |     |    |      |  |      |    |  |    |     |  |  |  |  |      |      |   |   |   |    |
| n/a   |  |     |    |     |    |      |  |      |    |  |    |     |  |  |  |  |      |      |   |   |   |    |
| n/a   |  |     |    |     |    |      |  |      |    |  |    |     |  |  |  |  |      |      |   |   |   |    |
| n/a   |  |     |    |     |    |      |  |      |    |  |    |     |  |  |  |  |      |      |   |   |   |    |
| n/a   |  |     |    |     |    |      |  |      |    |  |    |     |  |  |  |  |      |      |   |   |   |    |
| n/a   |  |     |    |     |    |      |  |      |    |  |    |     |  |  |  |  |      |      |   |   |   |    |
| Total |  | 799 | 47 | 846 | 38 | 2081 |  | 2119 | 60 |  | 48 | 108 |  |  |  |  | 3073 |      |   | 6 | 5 | 43 |

| Time Period Begins | Carey Rd NORTH Approach |      |       |       | Carey Rd SOUTH Approach |      |       |       | Harriet Rd WEST Approach |      |       |       | Harriet Rd EAST Approach |      |       |       | Total Volume |      | Ped<br>DL | Crosswalks |   |   |   | Conflict |     |
|--------------------|-------------------------|------|-------|-------|-------------------------|------|-------|-------|--------------------------|------|-------|-------|--------------------------|------|-------|-------|--------------|------|-----------|------------|---|---|---|----------|-----|
|                    | Left                    | Thru | Right | Total | Left                    | Thru | Right | Total | Left                     | Thru | Right | Total | Left                     | Thru | Right | Total | 15-min       | Hour |           | N          | S | W | E | 15 min   | Hr  |
| 7:30               |                         | 96   | 5     | 101   | 4                       | 28   |       | 32    | 3                        |      | 6     | 9     |                          |      |       |       | 142          |      |           | 1          | 0 | 5 |   | 111      |     |
| 7:45               |                         | 122  | 8     | 130   | 2                       | 43   |       | 45    | 1                        |      | 4     | 5     |                          |      |       |       | 180          | *    |           | 0          | 0 | 0 |   | 136      |     |
| 8:00               |                         | 130  | 7     | 137   | 0                       | 41   |       | 41    | 3                        |      | 4     | 7     |                          |      |       |       | 185          | +    |           | 1          | 0 | 2 |   | 141      |     |
| 8:15               |                         | 104  | 7     | 111   | 1                       | 58   |       | 59    | 8                        |      | 6     | 14    |                          |      |       |       | 184          | 691* |           | 1          | 0 | 0 |   | 120      | 508 |
| 8:30               |                         | 103  | 12    | 115   | 2                       | 37   |       | 39    | 4                        |      | 4     | 8     |                          |      |       |       | 162          | 711* |           | 0          | 0 | 1 |   | 121      | 518 |
| 8:45               |                         | 120  | 5     | 125   | 2                       | 40   |       | 42    | 3                        |      | 5     | 8     |                          |      |       |       | 175          | 706  |           | 1          | 1 | 3 |   | 132      | 514 |
| 9:00               |                         | 113  | 7     | 120   | 2                       | 51   |       | 53    | 3                        |      | 7     | 10    |                          |      |       |       | 183          | 704  |           | 3          | 1 | 5 |   | 129      | 502 |
| 9:15               |                         | 80   | 5     | 85    | 0                       | 45   |       | 45    | 4                        |      | 6     | 10    |                          |      |       |       | 140          | 660  |           | 0          | 0 | 4 |   | 91       | 473 |
| n/a                |                         |      |       |       |                         |      |       |       |                          |      |       |       |                          |      |       |       |              |      |           |            |   |   |   |          |     |
| n/a                |                         |      |       |       |                         |      |       |       |                          |      |       |       |                          |      |       |       |              |      |           |            |   |   |   |          |     |
| n/a                |                         |      |       |       |                         |      |       |       |                          |      |       |       |                          |      |       |       |              |      |           |            |   |   |   |          |     |
| n/a                |                         |      |       |       |                         |      |       |       |                          |      |       |       |                          |      |       |       |              |      |           |            |   |   |   |          |     |
| n/a                |                         |      |       |       |                         |      |       |       |                          |      |       |       |                          |      |       |       |              |      |           |            |   |   |   |          |     |
| n/a                |                         |      |       |       |                         |      |       |       |                          |      |       |       |                          |      |       |       |              |      |           |            |   |   |   |          |     |
| n/a                |                         |      |       |       |                         |      |       |       |                          |      |       |       |                          |      |       |       |              |      |           |            |   |   |   |          |     |
| n/a                |                         |      |       |       |                         |      |       |       |                          |      |       |       |                          |      |       |       |              |      |           |            |   |   |   |          |     |
| n/a                |                         |      |       |       |                         |      |       |       |                          |      |       |       |                          |      |       |       |              |      |           |            |   |   |   |          |     |
| n/a                |                         |      |       |       |                         |      |       |       |                          |      |       |       |                          |      |       |       |              |      |           |            |   |   |   |          |     |

|        |  |     |    |     |    |     |  |     |    |  |    |    |  |  |  |  |      |  |  |   |   |    |  |     |  |
|--------|--|-----|----|-----|----|-----|--|-----|----|--|----|----|--|--|--|--|------|--|--|---|---|----|--|-----|--|
| Total  |  | 868 | 56 | 924 | 13 | 343 |  | 356 | 29 |  | 42 | 71 |  |  |  |  | 1351 |  |  | 7 | 2 | 20 |  | 979 |  |
| Avg Hr |  | 434 | 28 | 462 | 7  | 172 |  | 178 | 15 |  | 21 | 36 |  |  |  |  | 676  |  |  | 4 | 1 | 10 |  |     |  |

**Peak hour of the intersection**

|       |  |      |      |             |      |      |  |             |      |  |      |             |  |  |  |  |      |   |  |      |     |      |  |      |  |
|-------|--|------|------|-------------|------|------|--|-------------|------|--|------|-------------|--|--|--|--|------|---|--|------|-----|------|--|------|--|
| Pk Hr |  | 459  | 34   | 493         | 5    | 179  |  | 184         | 16   |  | 18   | 34          |  |  |  |  | 711  | * |  | 2    | 0   | 3    |  | 516  |  |
| 15x4  |  | 520  | 48   | 548         | 8    | 232  |  | 236         | 32   |  | 24   | 56          |  |  |  |  | 740  | + |  | 4    | 0   | 8    |  | 608  |  |
| PHF   |  | 0.88 | 0.71 | <b>0.90</b> | 0.63 | 0.77 |  | <b>0.78</b> | 0.50 |  | 0.75 | <b>0.61</b> |  |  |  |  | 0.96 |   |  | 0.50 | n/a | 0.38 |  | 0.85 |  |

**Peak hour of conflicting volumes for the intersection**

|       |  |      |      |             |      |      |  |             |      |  |      |             |  |  |  |  |      |   |  |      |     |      |  |      |  |
|-------|--|------|------|-------------|------|------|--|-------------|------|--|------|-------------|--|--|--|--|------|---|--|------|-----|------|--|------|--|
| Pk Hr |  | 459  | 34   | 493         | 5    | 179  |  | 184         | 16   |  | 18   | 34          |  |  |  |  | 711  | * |  | 2    | 0   | 3    |  | 516  |  |
| 15x4  |  | 520  | 48   | 548         | 8    | 232  |  | 236         | 32   |  | 24   | 56          |  |  |  |  | 740  | + |  | 4    | 0   | 8    |  | 608  |  |
| PHF   |  | 0.88 | 0.71 | <b>0.90</b> | 0.63 | 0.77 |  | <b>0.78</b> | 0.50 |  | 0.75 | <b>0.61</b> |  |  |  |  | 0.96 |   |  | 0.50 | n/a | 0.38 |  | 0.85 |  |

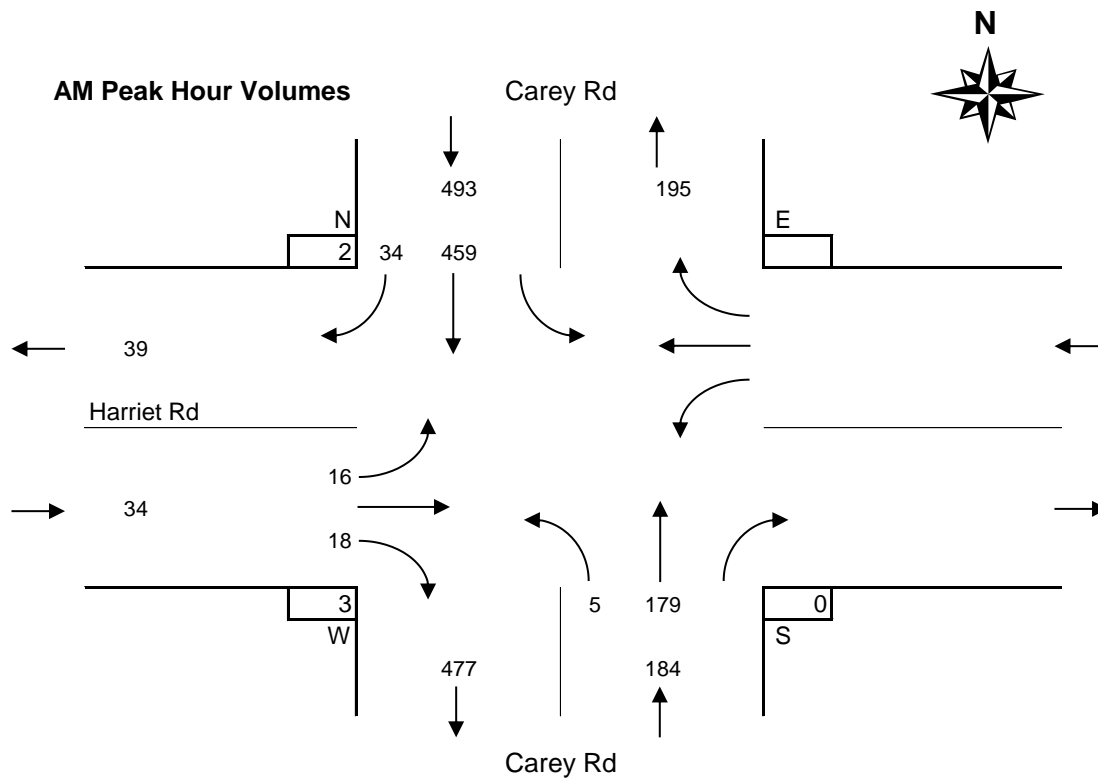

| Time<br>Period<br>Begins | Carey Rd       |      |       |       | Carey Rd       |      |       |       | Harriet Rd    |      |       |       | EAST Approach |      |       |       | Total Volume |      | Total<br>Ped<br>Adj | Crosswalks |   |   |   | Conflict |    |  |
|--------------------------|----------------|------|-------|-------|----------------|------|-------|-------|---------------|------|-------|-------|---------------|------|-------|-------|--------------|------|---------------------|------------|---|---|---|----------|----|--|
|                          | NORTH Approach |      |       |       | SOUTH Approach |      |       |       | WEST Approach |      |       |       | EAST Approach |      |       |       | 15-min       | Hour |                     | N          | S | W | E | 15 min   | Hr |  |
|                          | Left           | Thru | Right | Total | Left           | Thru | Right | Total | Left          | Thru | Right | Total | Left          | Thru | Right | Total | 15-min       | Hour |                     |            |   |   |   |          |    |  |
| n/a                      |                |      |       |       |                |      |       |       |               |      |       |       |               |      |       |       |              |      |                     |            |   |   |   |          |    |  |
| n/a                      |                |      |       |       |                |      |       |       |               |      |       |       |               |      |       |       |              |      |                     |            |   |   |   |          |    |  |
| n/a                      |                |      |       |       |                |      |       |       |               |      |       |       |               |      |       |       |              |      |                     |            |   |   |   |          |    |  |
| n/a                      |                |      |       |       |                |      |       |       |               |      |       |       |               |      |       |       |              |      |                     |            |   |   |   |          |    |  |
| n/a                      |                |      |       |       |                |      |       |       |               |      |       |       |               |      |       |       |              |      |                     |            |   |   |   |          |    |  |
| n/a                      |                |      |       |       |                |      |       |       |               |      |       |       |               |      |       |       |              |      |                     |            |   |   |   |          |    |  |
| n/a                      |                |      |       |       |                |      |       |       |               |      |       |       |               |      |       |       |              |      |                     |            |   |   |   |          |    |  |
| n/a                      |                |      |       |       |                |      |       |       |               |      |       |       |               |      |       |       |              |      |                     |            |   |   |   |          |    |  |
| n/a                      |                |      |       |       |                |      |       |       |               |      |       |       |               |      |       |       |              |      |                     |            |   |   |   |          |    |  |
| n/a                      |                |      |       |       |                |      |       |       |               |      |       |       |               |      |       |       |              |      |                     |            |   |   |   |          |    |  |
| n/a                      |                |      |       |       |                |      |       |       |               |      |       |       |               |      |       |       |              |      |                     |            |   |   |   |          |    |  |
| n/a                      |                |      |       |       |                |      |       |       |               |      |       |       |               |      |       |       |              |      |                     |            |   |   |   |          |    |  |
| n/a                      |                |      |       |       |                |      |       |       |               |      |       |       |               |      |       |       |              |      |                     |            |   |   |   |          |    |  |
| n/a                      |                |      |       |       |                |      |       |       |               |      |       |       |               |      |       |       |              |      |                     |            |   |   |   |          |    |  |

|        |  |  |  |  |  |  |  |  |  |  |  |  |  |  |  |  |  |  |  |  |  |  |  |  |  |  |
|--------|--|--|--|--|--|--|--|--|--|--|--|--|--|--|--|--|--|--|--|--|--|--|--|--|--|--|
| Total  |  |  |  |  |  |  |  |  |  |  |  |  |  |  |  |  |  |  |  |  |  |  |  |  |  |  |
| Avg Hr |  |  |  |  |  |  |  |  |  |  |  |  |  |  |  |  |  |  |  |  |  |  |  |  |  |  |

**Peak hour of the intersection**

|       |  |  |  |  |  |  |  |  |  |  |  |  |  |  |  |  |  |  |  |  |  |  |  |  |  |  |
|-------|--|--|--|--|--|--|--|--|--|--|--|--|--|--|--|--|--|--|--|--|--|--|--|--|--|--|
| Pk Hr |  |  |  |  |  |  |  |  |  |  |  |  |  |  |  |  |  |  |  |  |  |  |  |  |  |  |
| 15x4  |  |  |  |  |  |  |  |  |  |  |  |  |  |  |  |  |  |  |  |  |  |  |  |  |  |  |
| PHF   |  |  |  |  |  |  |  |  |  |  |  |  |  |  |  |  |  |  |  |  |  |  |  |  |  |  |

**Peak hour of conflicting volumes for the intersection**

|       |  |  |  |  |  |  |  |  |  |  |  |  |  |  |  |  |  |  |  |  |  |  |  |  |  |  |
|-------|--|--|--|--|--|--|--|--|--|--|--|--|--|--|--|--|--|--|--|--|--|--|--|--|--|--|
| Pk Hr |  |  |  |  |  |  |  |  |  |  |  |  |  |  |  |  |  |  |  |  |  |  |  |  |  |  |
| 15x4  |  |  |  |  |  |  |  |  |  |  |  |  |  |  |  |  |  |  |  |  |  |  |  |  |  |  |
| PHF   |  |  |  |  |  |  |  |  |  |  |  |  |  |  |  |  |  |  |  |  |  |  |  |  |  |  |

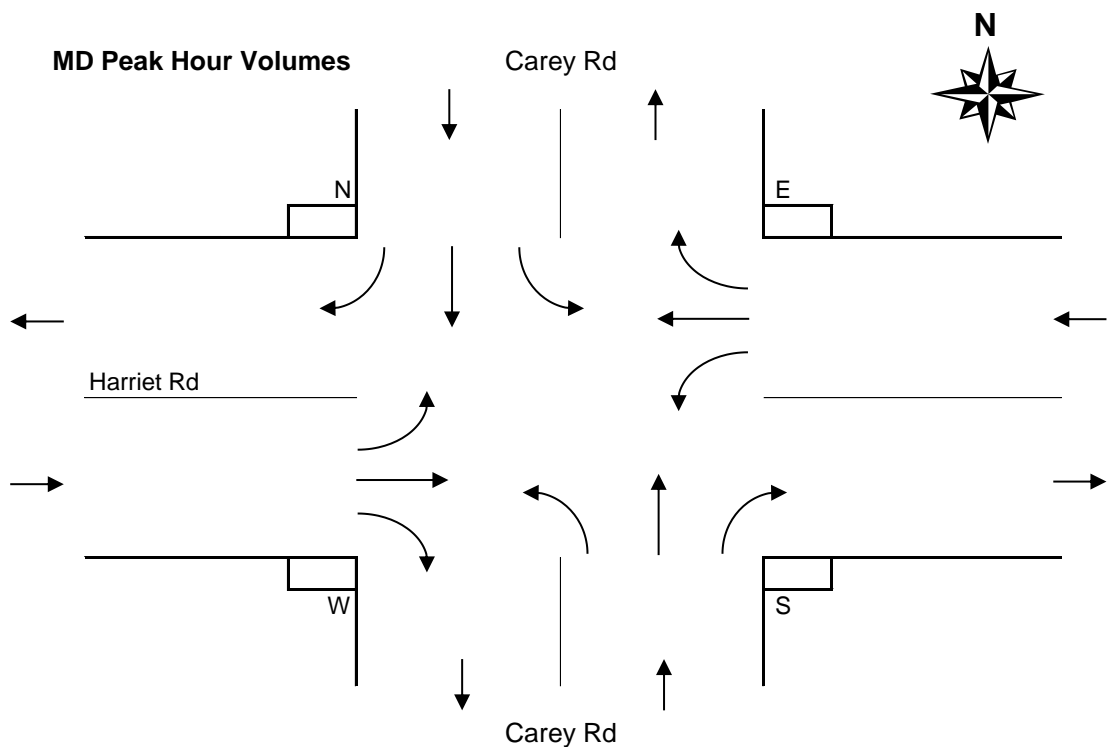

| Time Period Begins | Carey Rd NORTH Approach |      |       |       | Carey Rd SOUTH Approach |      |       |       | Harriet Rd WEST Approach |      |       |       | Harriet Rd EAST Approach |      |       |       | Total Volume |      | Pedestrians | Crosswalks |   |   |     | Conflict |    |
|--------------------|-------------------------|------|-------|-------|-------------------------|------|-------|-------|--------------------------|------|-------|-------|--------------------------|------|-------|-------|--------------|------|-------------|------------|---|---|-----|----------|----|
|                    | Left                    | Thru | Right | Total | Left                    | Thru | Right | Total | Left                     | Thru | Right | Total | Left                     | Thru | Right | Total | 15-min       | Hour |             | N          | S | W | E   | 15 min   | Hr |
| 15:30              |                         | 82   | 5     | 87    | 5                       | 158  |       | 163   | 7                        |      | 4     | 11    |                          |      |       |       | 261          |      | 0           | 0          | 4 |   | 165 |          |    |
| 15:45              |                         | 61   | 10    | 71    | 3                       | 192  |       | 195   | 6                        |      | 3     | 9     |                          |      |       |       | 275          |      | 1           | 0          | 4 |   | 198 |          |    |
| 16:00              |                         | 67   | 4     | 71    | 3                       | 200  |       | 203   | 7                        |      | 8     | 15    |                          |      |       |       | 289          |      | 1           | 0          | 4 |   | 208 |          |    |
| 16:15              |                         | 73   | 2     | 75    | 4                       | 216  |       | 220   | 7                        |      | 5     | 12    |                          |      |       |       | 307          | 1132 | 2           | 0          | 4 |   | 223 | 794      |    |
| 16:30              |                         | 64   | 4     | 68    | 3                       | 205  |       | 208   | 4                        |      | 1     | 5     |                          |      |       |       | 281          | 1152 | 0           | 0          | 2 |   | 209 | 838      |    |
| 16:45              |                         | 79   | 4     | 83    | 1                       | 202  |       | 203   | 6                        |      | 6     | 12    |                          |      |       |       | 298          | 1175 | 0           | 2          | 7 |   | 208 | 848      |    |
| 17:00              |                         | 65   | 4     | 69    | 0                       | 215  |       | 215   | 8                        |      | 7     | 15    |                          |      |       |       | 299          | 1185 | 0           | 1          | 1 |   | 223 | 863      |    |
| 17:15              |                         | 77   | 4     | 81    | 8                       | 184  |       | 192   | 1                        |      | 1     | 2     |                          |      |       |       | 275          | 1153 | 0           | 0          | 5 |   | 185 | 825      |    |
| 17:30              |                         | 70   | 3     | 73    | 3                       | 164  |       | 167   | 2                        |      | 5     | 7     |                          |      |       |       | 247          | 1119 | 0           | 0          | 1 |   | 169 | 785      |    |
| 17:45              |                         | 63   | 4     | 67    | 2                       | 113  |       | 115   | 8                        |      | 3     | 11    |                          |      |       |       | 193          | 1014 | 1           | 2          | 5 |   | 121 | 698      |    |
| 18:00              |                         | 60   | 0     | 60    | 3                       | 136  |       | 139   | 2                        |      | 4     | 6     |                          |      |       |       | 205          | 920  | 0           | 0          | 5 |   | 140 | 615      |    |
| 18:15              |                         | 38   | 3     | 41    | 3                       | 96   |       | 99    | 2                        |      | 1     | 3     |                          |      |       |       | 143          | 788  | 1           | 0          | 1 |   | 98  | 528      |    |
| n/a                |                         |      |       |       |                         |      |       |       |                          |      |       |       |                          |      |       |       |              |      |             |            |   |   |     |          |    |
| n/a                |                         |      |       |       |                         |      |       |       |                          |      |       |       |                          |      |       |       |              |      |             |            |   |   |     |          |    |
| n/a                |                         |      |       |       |                         |      |       |       |                          |      |       |       |                          |      |       |       |              |      |             |            |   |   |     |          |    |
| n/a                |                         |      |       |       |                         |      |       |       |                          |      |       |       |                          |      |       |       |              |      |             |            |   |   |     |          |    |
| n/a                |                         |      |       |       |                         |      |       |       |                          |      |       |       |                          |      |       |       |              |      |             |            |   |   |     |          |    |
| n/a                |                         |      |       |       |                         |      |       |       |                          |      |       |       |                          |      |       |       |              |      |             |            |   |   |     |          |    |
| n/a                |                         |      |       |       |                         |      |       |       |                          |      |       |       |                          |      |       |       |              |      |             |            |   |   |     |          |    |
| n/a                |                         |      |       |       |                         |      |       |       |                          |      |       |       |                          |      |       |       |              |      |             |            |   |   |     |          |    |
| n/a                |                         |      |       |       |                         |      |       |       |                          |      |       |       |                          |      |       |       |              |      |             |            |   |   |     |          |    |
| n/a                |                         |      |       |       |                         |      |       |       |                          |      |       |       |                          |      |       |       |              |      |             |            |   |   |     |          |    |
| n/a                |                         |      |       |       |                         |      |       |       |                          |      |       |       |                          |      |       |       |              |      |             |            |   |   |     |          |    |

|        |     |    |     |    |      |  |      |    |  |    |     |  |  |  |  |  |      |  |  |   |   |    |  |      |
|--------|-----|----|-----|----|------|--|------|----|--|----|-----|--|--|--|--|--|------|--|--|---|---|----|--|------|
| Total  | 799 | 47 | 846 | 38 | 2081 |  | 2119 | 60 |  | 48 | 108 |  |  |  |  |  | 3073 |  |  | 6 | 5 | 43 |  | 2141 |
| Avg Hr | 266 | 16 | 282 | 13 | 694  |  | 706  | 20 |  | 16 | 36  |  |  |  |  |  | 1024 |  |  | 2 | 2 | 14 |  |      |

Peak hour of the intersection

|       |      |      |      |      |      |  |      |      |  |      |      |  |  |  |  |  |      |  |  |      |      |      |  |      |
|-------|------|------|------|------|------|--|------|------|--|------|------|--|--|--|--|--|------|--|--|------|------|------|--|------|
| Pk Hr | 281  | 14   | 295  | 8    | 838  |  | 846  | 25   |  | 19   | 44   |  |  |  |  |  | 1185 |  |  | 2    | 3    | 14   |  | 863  |
| 15x4  | 316  | 16   | 332  | 16   | 864  |  | 880  | 32   |  | 28   | 60   |  |  |  |  |  | 1228 |  |  | 8    | 8    | 28   |  | 896  |
| PHF   | 0.89 | 0.88 | 0.89 | 0.50 | 0.97 |  | 0.96 | 0.78 |  | 0.68 | 0.73 |  |  |  |  |  | 0.96 |  |  | 0.25 | 0.38 | 0.50 |  | 0.96 |

Peak hour of conflicting volumes for the intersection

|       |      |      |      |      |      |  |      |      |  |      |      |  |  |  |  |  |      |  |  |      |      |      |  |      |
|-------|------|------|------|------|------|--|------|------|--|------|------|--|--|--|--|--|------|--|--|------|------|------|--|------|
| Pk Hr | 281  | 14   | 295  | 8    | 838  |  | 846  | 25   |  | 19   | 44   |  |  |  |  |  | 1185 |  |  | 2    | 3    | 14   |  | 863  |
| 15x4  | 316  | 16   | 332  | 16   | 864  |  | 880  | 32   |  | 28   | 60   |  |  |  |  |  | 1228 |  |  | 8    | 8    | 28   |  | 896  |
| PHF   | 0.89 | 0.88 | 0.89 | 0.50 | 0.97 |  | 0.96 | 0.78 |  | 0.68 | 0.73 |  |  |  |  |  | 0.96 |  |  | 0.25 | 0.38 | 0.50 |  | 0.96 |

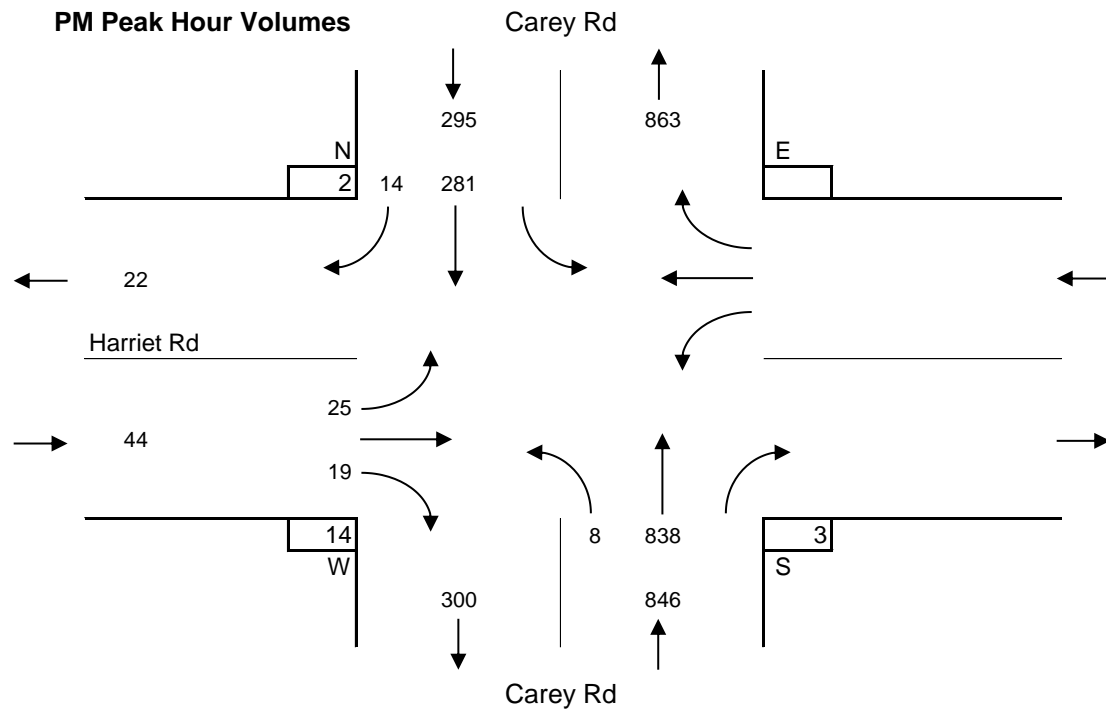

Entire Survey Period

5 Hours

|        | Carey Rd       |      |       |       | Carey Rd       |      |       |       | Harriet Rd    |      |       |       | EAST Approach |      |       |       | Total Volume | Crosswalks |    |    |   |
|--------|----------------|------|-------|-------|----------------|------|-------|-------|---------------|------|-------|-------|---------------|------|-------|-------|--------------|------------|----|----|---|
|        | NORTH Approach |      |       |       | SOUTH Approach |      |       |       | WEST Approach |      |       |       |               |      |       |       |              | N          | S  | W  | E |
|        | Left           | Thru | Right | Total | Left           | Thru | Right | Total | Left          | Thru | Right | Total | Left          | Thru | Right | Total |              |            |    |    |   |
| Total  |                | 1667 | 103   | 1770  | 51             | 2424 |       | 2475  | 89            |      | 90    | 179   |               |      |       |       | 4424         | 13         | 7  | 63 |   |
| Avg Hr |                | 333  | 21    | 354   | 10             | 485  |       | 495   | 18            |      | 18    | 36    |               |      |       | 885   | 3            | 1          | 13 |    |   |

AM Peak Period

2 Hours

|        | Carey Rd       |      |       |       | Carey Rd       |      |       |       | Harriet Rd    |      |       |       | EAST Approach |      |       |       | Total Volume | Crosswalks |    |   |   |
|--------|----------------|------|-------|-------|----------------|------|-------|-------|---------------|------|-------|-------|---------------|------|-------|-------|--------------|------------|----|---|---|
|        | NORTH Approach |      |       |       | SOUTH Approach |      |       |       | WEST Approach |      |       |       |               |      |       |       |              | N          | S  | W | E |
|        | Left           | Thru | Right | Total | Left           | Thru | Right | Total | Left          | Thru | Right | Total | Left          | Thru | Right | Total |              |            |    |   |   |
| Totals |                | 868  | 56    | 924   | 13             | 343  |       | 356   | 29            |      | 42    | 71    |               |      |       | 1351  | 7            | 2          | 20 |   |   |
| Avg Hr |                | 434  | 28    | 462   | 7              | 172  |       | 178   | 15            |      | 21    | 36    |               |      |       | 676   | 4            | 1          | 10 |   |   |

MD Peak Period

Hours

|        | Carey Rd       |      |       |       | Carey Rd       |      |       |       | Harriet Rd    |      |       |       | EAST Approach |      |       |       | Total Volume | Crosswalks |   |   |   |
|--------|----------------|------|-------|-------|----------------|------|-------|-------|---------------|------|-------|-------|---------------|------|-------|-------|--------------|------------|---|---|---|
|        | NORTH Approach |      |       |       | SOUTH Approach |      |       |       | WEST Approach |      |       |       |               |      |       |       |              | N          | S | W | E |
|        | Left           | Thru | Right | Total | Left           | Thru | Right | Total | Left          | Thru | Right | Total | Left          | Thru | Right | Total |              |            |   |   |   |
| Total  |                |      |       |       |                |      |       |       |               |      |       |       |               |      |       |       |              |            |   |   |   |
| Avg Hr |                |      |       |       |                |      |       |       |               |      |       |       |               |      |       |       |              |            |   |   |   |

PM Peak Period

3 Hours

|        | Carey Rd       |      |       |       | Carey Rd       |      |       |       | Harriet Rd    |      |       |       | EAST Approach |      |       |       | Total Volume | Crosswalks |    |   |   |
|--------|----------------|------|-------|-------|----------------|------|-------|-------|---------------|------|-------|-------|---------------|------|-------|-------|--------------|------------|----|---|---|
|        | NORTH Approach |      |       |       | SOUTH Approach |      |       |       | WEST Approach |      |       |       |               |      |       |       |              | N          | S  | W | E |
|        | Left           | Thru | Right | Total | Left           | Thru | Right | Total | Left          | Thru | Right | Total | Left          | Thru | Right | Total |              |            |    |   |   |
| Total  |                | 799  | 47    | 846   | 38             | 2081 |       | 2119  | 60            |      | 48    | 108   |               |      |       | 3073  | 6            | 5          | 43 |   |   |
| Avg Hr |                | 266  | 16    | 282   | 13             | 694  |       | 706   | 20            |      | 16    | 36    |               |      | 1024  | 2     | 2            | 14         |    |   |   |

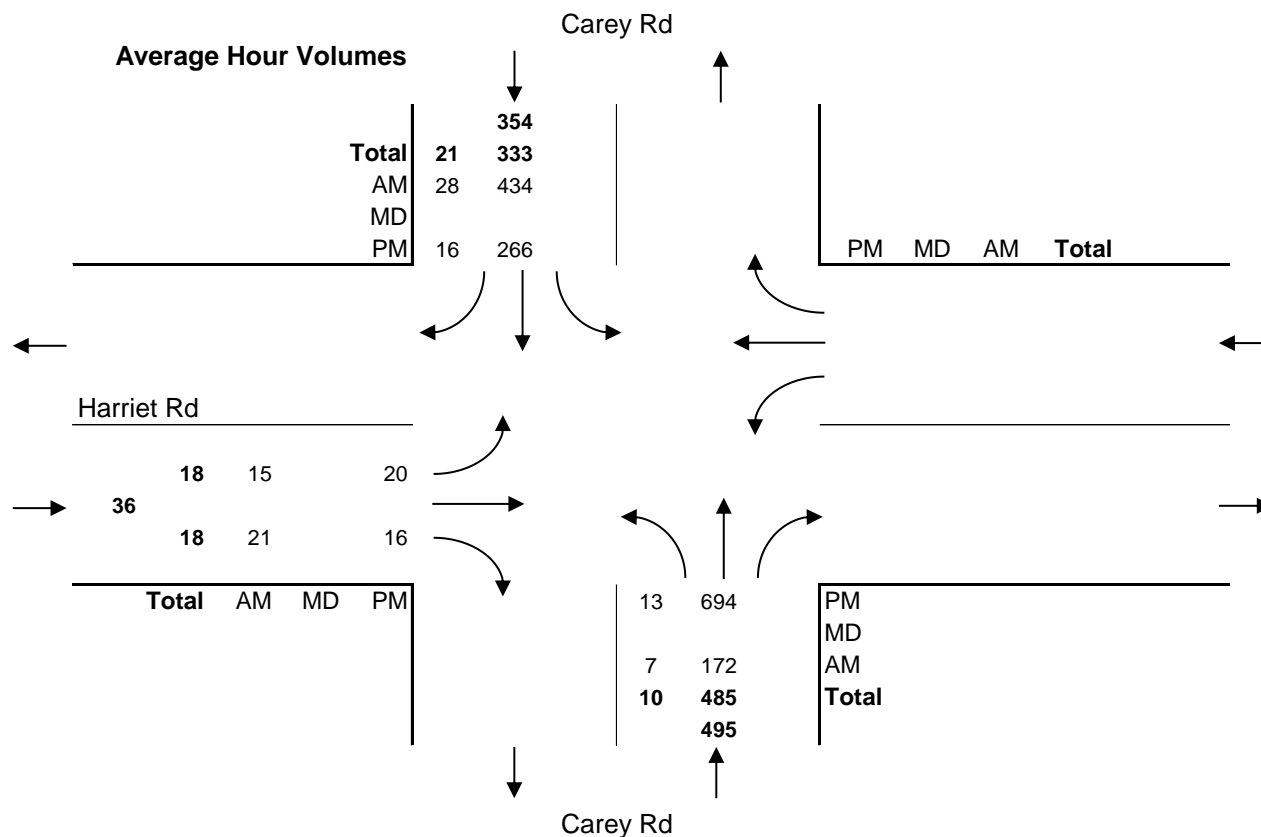

**Major Route:** Carey Road  
**Minor Route:** Harriet Road  
**Municipality:** Saanich  
**Filename:** Carey Rd @ Harriet Rd-Apr 3, 2019.xlsx  
**Location #:** TIN001139  
**Count ID:** 2019004  
**Date:** April 3, 2019  
**Day-of-week:** Wednesday

**East/West Route:** Harriet Road  
**Intersection Type:** 4-leg  
**Signalized?:** No  
**Weather:** Overcast and dry

**Vehicle Classifications:** Vehicles and Peds  
 Bikes

**This data is for Bikes**

| Shift        | Start       | End          | Duration    |
|--------------|-------------|--------------|-------------|
| AM           | 7:30        | 9:30         | 2.00        |
| MD           |             |              |             |
| PM           | 15:30       | 18:30        | 3.00        |
| <b>Total</b> | <b>7:30</b> | <b>18:30</b> | <b>5.00</b> |

**Notes:** 24-hour clock used for reporting (15-minute increments)  
 North Approach - southbound vehicles approaching intersection from the north  
 15x4 - 15 min volume (from maximum 15 minute period of movement/approach in peak hour period [\*]) x 4  
 Pedestrians - N indicates pedestrians crossing north approach (east/west)

**Comments:**



**Survey Data**  
**Bikes**

**Carey Road @ Harriet Road**  
**Wednesday, April 3, 2019**

| Time Period Begins | Carey Rd NORTH Approach |      |       |       | Carey Rd SOUTH Approach |      |       |       | Harriet Rd WEST Approach |      |       |       | EAST Approach |      |       |       | Total Volume |      | Day of Week | N | S | W | E |
|--------------------|-------------------------|------|-------|-------|-------------------------|------|-------|-------|--------------------------|------|-------|-------|---------------|------|-------|-------|--------------|------|-------------|---|---|---|---|
|                    | Left                    | Thru | Right | Total | Left                    | Thru | Right | Total | Left                     | Thru | Right | Total | Left          | Thru | Right | Total | 15-min       | Hour |             |   |   |   |   |
| 7:30               | 0                       | 5    | 0     | 5     | 0                       | 1    | 0     | 1     | 0                        | 0    | 2     | 2     | 0             | 0    | 0     | 0     | 8            |      | 0           | 0 | 0 | 0 |   |
| 7:45               | 0                       | 7    | 0     | 7     | 0                       | 2    | 0     | 2     | 0                        | 0    | 0     | 0     | 0             | 0    | 0     | 0     | 9            | *    | 0           | 0 | 0 | 0 |   |
| 8:00               | 0                       | 7    | 0     | 7     | 0                       | 1    | 0     | 1     | 0                        | 0    | 0     | 0     | 0             | 0    | 0     | 0     | 8            | *    | 0           | 0 | 0 | 0 |   |
| 8:15               | 0                       | 7    | 0     | 7     | 0                       | 6    | 0     | 6     | 0                        | 0    | 1     | 1     | 0             | 0    | 0     | 0     | 14           | 39+  | 0           | 0 | 0 | 0 |   |
| 8:30               | 0                       | 7    | 0     | 7     | 0                       | 1    | 0     | 1     | 0                        | 0    | 1     | 1     | 0             | 0    | 0     | 0     | 9            | 40*  | 0           | 0 | 0 | 0 |   |
| 8:45               | 0                       | 4    | 0     | 4     | 0                       | 1    | 0     | 1     | 0                        | 0    | 1     | 1     | 0             | 0    | 0     | 0     | 6            | 37   | 0           | 0 | 0 | 0 |   |
| 9:00               | 0                       | 3    | 0     | 3     | 0                       | 0    | 0     | 0     | 0                        | 0    | 0     | 0     | 0             | 0    | 0     | 0     | 3            | 32   | 0           | 0 | 0 | 0 |   |
| 9:15               | 0                       | 4    | 0     | 4     | 0                       | 0    | 0     | 0     | 0                        | 0    | 0     | 0     | 0             | 0    | 0     | 0     | 4            | 22   | 0           | 0 | 0 | 0 |   |
| n/a                |                         |      |       |       |                         |      |       |       |                          |      |       |       |               |      |       |       |              |      |             |   |   |   |   |
| n/a                |                         |      |       |       |                         |      |       |       |                          |      |       |       |               |      |       |       |              |      |             |   |   |   |   |
| n/a                |                         |      |       |       |                         |      |       |       |                          |      |       |       |               |      |       |       |              |      |             |   |   |   |   |
| n/a                |                         |      |       |       |                         |      |       |       |                          |      |       |       |               |      |       |       |              |      |             |   |   |   |   |
| n/a                |                         |      |       |       |                         |      |       |       |                          |      |       |       |               |      |       |       |              |      |             |   |   |   |   |
| n/a                |                         |      |       |       |                         |      |       |       |                          |      |       |       |               |      |       |       |              |      |             |   |   |   |   |
| n/a                |                         |      |       |       |                         |      |       |       |                          |      |       |       |               |      |       |       |              |      |             |   |   |   |   |
| n/a                |                         |      |       |       |                         |      |       |       |                          |      |       |       |               |      |       |       |              |      |             |   |   |   |   |
| n/a                |                         |      |       |       |                         |      |       |       |                          |      |       |       |               |      |       |       |              |      |             |   |   |   |   |
| n/a                |                         |      |       |       |                         |      |       |       |                          |      |       |       |               |      |       |       |              |      |             |   |   |   |   |
| n/a                |                         |      |       |       |                         |      |       |       |                          |      |       |       |               |      |       |       |              |      |             |   |   |   |   |
| n/a                |                         |      |       |       |                         |      |       |       |                          |      |       |       |               |      |       |       |              |      |             |   |   |   |   |
| n/a                |                         |      |       |       |                         |      |       |       |                          |      |       |       |               |      |       |       |              |      |             |   |   |   |   |
| n/a                |                         |      |       |       |                         |      |       |       |                          |      |       |       |               |      |       |       |              |      |             |   |   |   |   |
| Total              | 0                       | 44   | 0     | 44    | 0                       | 12   | 0     | 12    | 0                        | 0    | 5     | 5     | 0             | 0    | 0     | 0     | 61           |      | 0           | 0 | 0 | 0 |   |

|       |  |  |  |  |  |  |  |  |  |  |  |  |  |  |  |  |  |  |  |  |  |  |
|-------|--|--|--|--|--|--|--|--|--|--|--|--|--|--|--|--|--|--|--|--|--|--|
| n/a   |  |  |  |  |  |  |  |  |  |  |  |  |  |  |  |  |  |  |  |  |  |  |
| n/a   |  |  |  |  |  |  |  |  |  |  |  |  |  |  |  |  |  |  |  |  |  |  |
| n/a   |  |  |  |  |  |  |  |  |  |  |  |  |  |  |  |  |  |  |  |  |  |  |
| n/a   |  |  |  |  |  |  |  |  |  |  |  |  |  |  |  |  |  |  |  |  |  |  |
| n/a   |  |  |  |  |  |  |  |  |  |  |  |  |  |  |  |  |  |  |  |  |  |  |
| n/a   |  |  |  |  |  |  |  |  |  |  |  |  |  |  |  |  |  |  |  |  |  |  |
| n/a   |  |  |  |  |  |  |  |  |  |  |  |  |  |  |  |  |  |  |  |  |  |  |
| n/a   |  |  |  |  |  |  |  |  |  |  |  |  |  |  |  |  |  |  |  |  |  |  |
| n/a   |  |  |  |  |  |  |  |  |  |  |  |  |  |  |  |  |  |  |  |  |  |  |
| n/a   |  |  |  |  |  |  |  |  |  |  |  |  |  |  |  |  |  |  |  |  |  |  |
| n/a   |  |  |  |  |  |  |  |  |  |  |  |  |  |  |  |  |  |  |  |  |  |  |
| n/a   |  |  |  |  |  |  |  |  |  |  |  |  |  |  |  |  |  |  |  |  |  |  |
| n/a   |  |  |  |  |  |  |  |  |  |  |  |  |  |  |  |  |  |  |  |  |  |  |
| n/a   |  |  |  |  |  |  |  |  |  |  |  |  |  |  |  |  |  |  |  |  |  |  |
| n/a   |  |  |  |  |  |  |  |  |  |  |  |  |  |  |  |  |  |  |  |  |  |  |
| n/a   |  |  |  |  |  |  |  |  |  |  |  |  |  |  |  |  |  |  |  |  |  |  |
| Total |  |  |  |  |  |  |  |  |  |  |  |  |  |  |  |  |  |  |  |  |  |  |

|       |   |    |   |    |   |    |   |    |   |   |   |   |   |   |   |   |    |     |   |   |   |   |
|-------|---|----|---|----|---|----|---|----|---|---|---|---|---|---|---|---|----|-----|---|---|---|---|
| 15:30 | 0 | 0  | 0 | 0  | 0 | 6  | 0 | 6  | 0 | 0 | 0 | 0 | 0 | 0 | 0 | 0 | 6  |     | 0 | 0 | 0 | 0 |
| 15:45 | 0 | 1  | 0 | 1  | 0 | 1  | 0 | 1  | 0 | 0 | 0 | 0 | 0 | 0 | 0 | 0 | 2  |     | 0 | 0 | 0 | 0 |
| 16:00 | 0 | 1  | 0 | 1  | 0 | 2  | 0 | 2  | 0 | 0 | 0 | 0 | 0 | 0 | 0 | 0 | 3  |     | 0 | 0 | 0 | 0 |
| 16:15 | 0 | 1  | 0 | 1  | 0 | 7  | 0 | 7  | 0 | 0 | 0 | 0 | 0 | 0 | 0 | 0 | 8  | 19* | 0 | 0 | 0 | 0 |
| 16:30 | 0 | 1  | 0 | 1  | 1 | 8  | 0 | 9  | 0 | 0 | 0 | 0 | 0 | 0 | 0 | 0 | 10 | 23* | 0 | 0 | 0 | 0 |
| 16:45 | 0 | 4  | 0 | 4  | 0 | 11 | 0 | 11 | 2 | 0 | 0 | 2 | 0 | 0 | 0 | 0 | 17 | 38+ | 0 | 0 | 0 | 0 |
| 17:00 | 0 | 3  | 0 | 3  | 1 | 5  | 0 | 6  | 0 | 0 | 0 | 0 | 0 | 0 | 0 | 0 | 9  | 44* | 0 | 0 | 0 | 0 |
| 17:15 | 0 | 0  | 0 | 0  | 1 | 3  | 0 | 4  | 0 | 0 | 0 | 0 | 0 | 0 | 0 | 0 | 4  | 40  | 0 | 0 | 0 | 0 |
| 17:30 | 0 | 1  | 0 | 1  | 0 | 1  | 0 | 1  | 0 | 0 | 0 | 0 | 0 | 0 | 0 | 0 | 2  | 32  | 0 | 0 | 0 | 0 |
| 17:45 | 0 | 1  | 0 | 1  | 1 | 7  | 0 | 8  | 0 | 0 | 0 | 0 | 0 | 0 | 0 | 0 | 9  | 24  | 0 | 0 | 0 | 0 |
| 18:00 | 0 | 3  | 0 | 3  | 0 | 1  | 0 | 1  | 0 | 0 | 0 | 0 | 0 | 0 | 0 | 0 | 4  | 19  | 0 | 0 | 0 | 0 |
| 18:15 | 0 | 0  | 0 | 0  | 0 | 2  | 0 | 2  | 0 | 0 | 0 | 0 | 0 | 0 | 0 | 0 | 2  | 17  | 0 | 0 | 0 | 0 |
| n/a   |   |    |   |    |   |    |   |    |   |   |   |   |   |   |   |   |    |     |   |   |   |   |
| n/a   |   |    |   |    |   |    |   |    |   |   |   |   |   |   |   |   |    |     |   |   |   |   |
| n/a   |   |    |   |    |   |    |   |    |   |   |   |   |   |   |   |   |    |     |   |   |   |   |
| n/a   |   |    |   |    |   |    |   |    |   |   |   |   |   |   |   |   |    |     |   |   |   |   |
| n/a   |   |    |   |    |   |    |   |    |   |   |   |   |   |   |   |   |    |     |   |   |   |   |
| n/a   |   |    |   |    |   |    |   |    |   |   |   |   |   |   |   |   |    |     |   |   |   |   |
| n/a   |   |    |   |    |   |    |   |    |   |   |   |   |   |   |   |   |    |     |   |   |   |   |
| n/a   |   |    |   |    |   |    |   |    |   |   |   |   |   |   |   |   |    |     |   |   |   |   |
| n/a   |   |    |   |    |   |    |   |    |   |   |   |   |   |   |   |   |    |     |   |   |   |   |
| n/a   |   |    |   |    |   |    |   |    |   |   |   |   |   |   |   |   |    |     |   |   |   |   |
| Total | 0 | 16 | 0 | 16 | 4 | 54 | 0 | 58 | 2 | 0 | 0 | 2 | 0 | 0 | 0 | 0 | 76 |     | 0 | 0 | 0 | 0 |

**AM Peak Period**  
Bikes

| Time Period Begins | Carey Rd NORTH Approach |      |       |       | Carey Rd SOUTH Approach |      |       |       | Harriet Rd WEST Approach |      |       |       | Harriet Rd EAST Approach |      |       |       | Total Volume |      | % Sat | Conflict |   |   |   |        |
|--------------------|-------------------------|------|-------|-------|-------------------------|------|-------|-------|--------------------------|------|-------|-------|--------------------------|------|-------|-------|--------------|------|-------|----------|---|---|---|--------|
|                    | Left                    | Thru | Right | Total | Left                    | Thru | Right | Total | Left                     | Thru | Right | Total | Left                     | Thru | Right | Total | 15-min       | Hour |       | N        | S | W | E | 15 min |
| 7:30               | 0                       | 5    | 0     | 5     | 0                       | 1    | 0     | 1     | 0                        | 0    | 2     | 2     | 0                        | 0    | 0     | 0     | 8            |      | 0     | 0        | 0 | 0 | 7 |        |
| 7:45               | 0                       | 7    | 0     | 7     | 0                       | 2    | 0     | 2     | 0                        | 0    | 0     | 0     | 0                        | 0    | 0     | 0     | 9            | *    | 0     | 0        | 0 | 0 | 7 |        |
| 8:00               | 0                       | 7    | 0     | 7     | 0                       | 1    | 0     | 1     | 0                        | 0    | 0     | 0     | 0                        | 0    | 0     | 0     | 8            | *    | 0     | 0        | 0 | 0 | 7 |        |
| 8:15               | 0                       | 7    | 0     | 7     | 0                       | 6    | 0     | 6     | 0                        | 0    | 1     | 1     | 0                        | 0    | 0     | 0     | 14           | 39+  | 0     | 0        | 0 | 0 | 8 | 29     |
| 8:30               | 0                       | 7    | 0     | 7     | 0                       | 1    | 0     | 1     | 0                        | 0    | 1     | 1     | 0                        | 0    | 0     | 0     | 9            | 40*  | 0     | 0        | 0 | 0 | 8 | 30     |
| 8:45               | 0                       | 4    | 0     | 4     | 0                       | 1    | 0     | 1     | 0                        | 0    | 1     | 1     | 0                        | 0    | 0     | 0     | 6            | 37   | 0     | 0        | 0 | 0 | 5 | 28     |
| 9:00               | 0                       | 3    | 0     | 3     | 0                       | 0    | 0     | 0     | 0                        | 0    | 0     | 0     | 0                        | 0    | 0     | 0     | 3            | 32   | 0     | 0        | 0 | 0 | 3 | 24     |
| 9:15               | 0                       | 4    | 0     | 4     | 0                       | 0    | 0     | 0     | 0                        | 0    | 0     | 0     | 0                        | 0    | 0     | 0     | 4            | 22   | 0     | 0        | 0 | 0 | 4 | 20     |
| n/a                |                         |      |       |       |                         |      |       |       |                          |      |       |       |                          |      |       |       |              |      |       |          |   |   |   |        |
| n/a                |                         |      |       |       |                         |      |       |       |                          |      |       |       |                          |      |       |       |              |      |       |          |   |   |   |        |
| n/a                |                         |      |       |       |                         |      |       |       |                          |      |       |       |                          |      |       |       |              |      |       |          |   |   |   |        |
| n/a                |                         |      |       |       |                         |      |       |       |                          |      |       |       |                          |      |       |       |              |      |       |          |   |   |   |        |
| n/a                |                         |      |       |       |                         |      |       |       |                          |      |       |       |                          |      |       |       |              |      |       |          |   |   |   |        |
| n/a                |                         |      |       |       |                         |      |       |       |                          |      |       |       |                          |      |       |       |              |      |       |          |   |   |   |        |
| n/a                |                         |      |       |       |                         |      |       |       |                          |      |       |       |                          |      |       |       |              |      |       |          |   |   |   |        |
| n/a                |                         |      |       |       |                         |      |       |       |                          |      |       |       |                          |      |       |       |              |      |       |          |   |   |   |        |
| n/a                |                         |      |       |       |                         |      |       |       |                          |      |       |       |                          |      |       |       |              |      |       |          |   |   |   |        |
| n/a                |                         |      |       |       |                         |      |       |       |                          |      |       |       |                          |      |       |       |              |      |       |          |   |   |   |        |
| n/a                |                         |      |       |       |                         |      |       |       |                          |      |       |       |                          |      |       |       |              |      |       |          |   |   |   |        |
| n/a                |                         |      |       |       |                         |      |       |       |                          |      |       |       |                          |      |       |       |              |      |       |          |   |   |   |        |
| n/a                |                         |      |       |       |                         |      |       |       |                          |      |       |       |                          |      |       |       |              |      |       |          |   |   |   |        |
| n/a                |                         |      |       |       |                         |      |       |       |                          |      |       |       |                          |      |       |       |              |      |       |          |   |   |   |        |
| n/a                |                         |      |       |       |                         |      |       |       |                          |      |       |       |                          |      |       |       |              |      |       |          |   |   |   |        |
| n/a                |                         |      |       |       |                         |      |       |       |                          |      |       |       |                          |      |       |       |              |      |       |          |   |   |   |        |

|        |   |    |   |    |   |    |   |    |   |   |   |   |   |   |   |   |    |  |   |   |   |   |  |    |
|--------|---|----|---|----|---|----|---|----|---|---|---|---|---|---|---|---|----|--|---|---|---|---|--|----|
| Total  | 0 | 44 | 0 | 44 | 0 | 12 | 0 | 12 | 0 | 0 | 5 | 5 | 0 | 0 | 0 | 0 | 61 |  | 0 | 0 | 0 | 0 |  | 49 |
| Avg Hr | 0 | 22 | 0 | 22 | 0 | 6  | 0 | 6  | 0 | 0 | 3 | 3 | 0 | 0 | 0 | 0 | 31 |  | 0 | 0 | 0 | 0 |  |    |

**Peak hour of the intersection**

|       |     |      |     |      |     |      |     |      |     |     |      |      |     |     |     |     |      |  |     |     |     |     |  |      |
|-------|-----|------|-----|------|-----|------|-----|------|-----|-----|------|------|-----|-----|-----|-----|------|--|-----|-----|-----|-----|--|------|
| Pk Hr | 0   | 28   | 0   | 28   | 0   | 10   | 0   | 10   | 0   | 0   | 2    | 2    | 0   | 0   | 0   | 0   | 40*  |  | 0   | 0   | 0   | 0   |  | 30   |
| 15x4  | 0   | 28   | 0   | 28   | 0   | 24   | 0   | 24   | 0   | 0   | 4    | 4    | 0   | 0   | 0   | 0   | 56+  |  | 0   | 0   | 0   | 0   |  | 32   |
| PHF   | n/a | 1.00 | n/a | 1.00 | n/a | 0.42 | n/a | 0.42 | n/a | n/a | 0.50 | 0.50 | n/a | n/a | n/a | n/a | 0.71 |  | n/a | n/a | n/a | n/a |  | 0.94 |

**Peak hour of conflicting volumes for the intersection**

|       |     |      |     |      |     |      |     |      |     |     |      |      |     |     |     |     |      |  |     |     |     |     |  |      |
|-------|-----|------|-----|------|-----|------|-----|------|-----|-----|------|------|-----|-----|-----|-----|------|--|-----|-----|-----|-----|--|------|
| Pk Hr | 0   | 28   | 0   | 28   | 0   | 10   | 0   | 10   | 0   | 0   | 2    | 2    | 0   | 0   | 0   | 0   | 40*  |  | 0   | 0   | 0   | 0   |  | 30   |
| 15x4  | 0   | 28   | 0   | 28   | 0   | 24   | 0   | 24   | 0   | 0   | 4    | 4    | 0   | 0   | 0   | 0   | 56+  |  | 0   | 0   | 0   | 0   |  | 32   |
| PHF   | n/a | 1.00 | n/a | 1.00 | n/a | 0.42 | n/a | 0.42 | n/a | n/a | 0.50 | 0.50 | n/a | n/a | n/a | n/a | 0.71 |  | n/a | n/a | n/a | n/a |  | 0.94 |

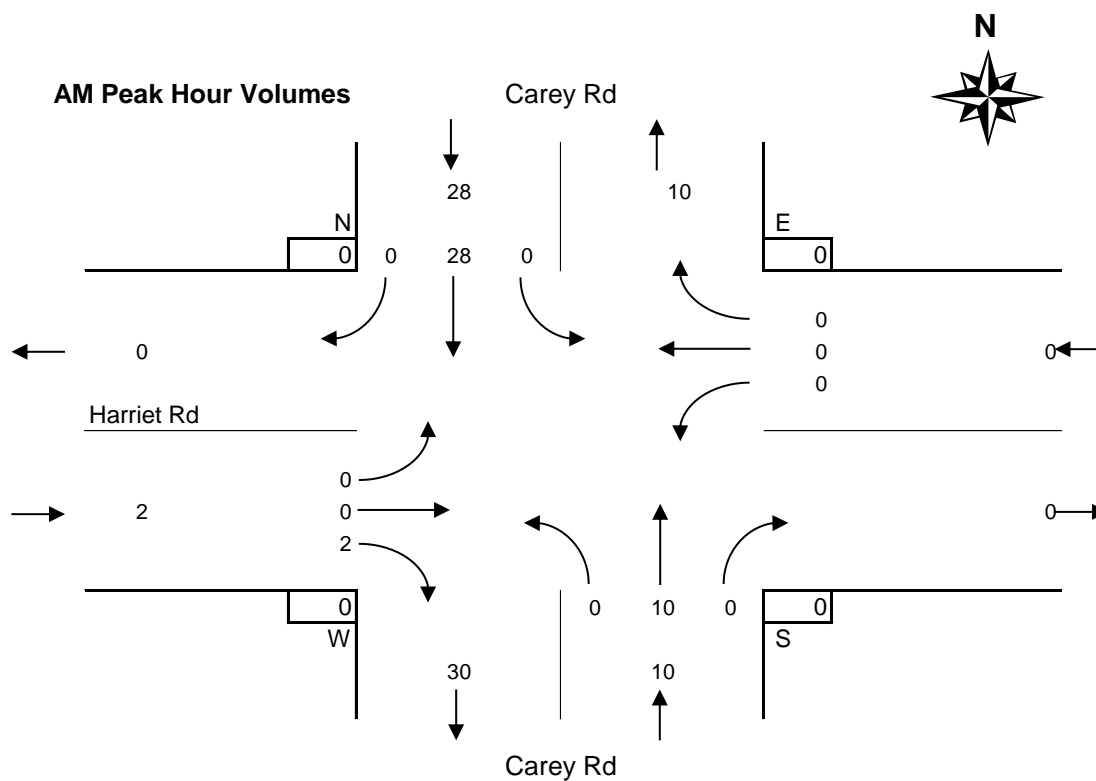

| Time Period Begins | Carey Rd NORTH Approach |      |       |       | Carey Rd SOUTH Approach |      |       |       | Harriet Rd WEST Approach |      |       |       | Harriet Rd EAST Approach |      |       |       | Total Volume |      | Day of Week | Conflict |   |   |   |        |    |
|--------------------|-------------------------|------|-------|-------|-------------------------|------|-------|-------|--------------------------|------|-------|-------|--------------------------|------|-------|-------|--------------|------|-------------|----------|---|---|---|--------|----|
|                    | Left                    | Thru | Right | Total | Left                    | Thru | Right | Total | Left                     | Thru | Right | Total | Left                     | Thru | Right | Total | 15-min       | Hour |             | N        | S | W | E | 15 min | Hr |
|                    | n/a                     |      |       |       |                         |      |       |       |                          |      |       |       |                          |      |       |       |              |      |             |          |   |   |   |        |    |
| n/a                |                         |      |       |       |                         |      |       |       |                          |      |       |       |                          |      |       |       |              |      |             |          |   |   |   |        |    |
| n/a                |                         |      |       |       |                         |      |       |       |                          |      |       |       |                          |      |       |       |              |      |             |          |   |   |   |        |    |
| n/a                |                         |      |       |       |                         |      |       |       |                          |      |       |       |                          |      |       |       |              |      |             |          |   |   |   |        |    |
| n/a                |                         |      |       |       |                         |      |       |       |                          |      |       |       |                          |      |       |       |              |      |             |          |   |   |   |        |    |
| n/a                |                         |      |       |       |                         |      |       |       |                          |      |       |       |                          |      |       |       |              |      |             |          |   |   |   |        |    |
| n/a                |                         |      |       |       |                         |      |       |       |                          |      |       |       |                          |      |       |       |              |      |             |          |   |   |   |        |    |
| n/a                |                         |      |       |       |                         |      |       |       |                          |      |       |       |                          |      |       |       |              |      |             |          |   |   |   |        |    |
| n/a                |                         |      |       |       |                         |      |       |       |                          |      |       |       |                          |      |       |       |              |      |             |          |   |   |   |        |    |
| n/a                |                         |      |       |       |                         |      |       |       |                          |      |       |       |                          |      |       |       |              |      |             |          |   |   |   |        |    |
| n/a                |                         |      |       |       |                         |      |       |       |                          |      |       |       |                          |      |       |       |              |      |             |          |   |   |   |        |    |
| n/a                |                         |      |       |       |                         |      |       |       |                          |      |       |       |                          |      |       |       |              |      |             |          |   |   |   |        |    |
| n/a                |                         |      |       |       |                         |      |       |       |                          |      |       |       |                          |      |       |       |              |      |             |          |   |   |   |        |    |
| n/a                |                         |      |       |       |                         |      |       |       |                          |      |       |       |                          |      |       |       |              |      |             |          |   |   |   |        |    |
| n/a                |                         |      |       |       |                         |      |       |       |                          |      |       |       |                          |      |       |       |              |      |             |          |   |   |   |        |    |
| n/a                |                         |      |       |       |                         |      |       |       |                          |      |       |       |                          |      |       |       |              |      |             |          |   |   |   |        |    |

|        |  |  |  |  |  |  |  |  |  |  |  |  |  |  |  |  |  |  |  |  |  |  |  |  |  |
|--------|--|--|--|--|--|--|--|--|--|--|--|--|--|--|--|--|--|--|--|--|--|--|--|--|--|
| Total  |  |  |  |  |  |  |  |  |  |  |  |  |  |  |  |  |  |  |  |  |  |  |  |  |  |
| Avg Hr |  |  |  |  |  |  |  |  |  |  |  |  |  |  |  |  |  |  |  |  |  |  |  |  |  |

**Peak hour of the intersection**

|       |  |  |  |  |  |  |  |  |  |  |  |  |  |  |  |  |  |  |  |  |  |  |  |  |  |
|-------|--|--|--|--|--|--|--|--|--|--|--|--|--|--|--|--|--|--|--|--|--|--|--|--|--|
| Pk Hr |  |  |  |  |  |  |  |  |  |  |  |  |  |  |  |  |  |  |  |  |  |  |  |  |  |
| 15x4  |  |  |  |  |  |  |  |  |  |  |  |  |  |  |  |  |  |  |  |  |  |  |  |  |  |
| PHF   |  |  |  |  |  |  |  |  |  |  |  |  |  |  |  |  |  |  |  |  |  |  |  |  |  |

**Peak hour of conflicting volumes for the intersection**

|       |  |  |  |  |  |  |  |  |  |  |  |  |  |  |  |  |  |  |  |  |  |  |  |  |  |
|-------|--|--|--|--|--|--|--|--|--|--|--|--|--|--|--|--|--|--|--|--|--|--|--|--|--|
| Pk Hr |  |  |  |  |  |  |  |  |  |  |  |  |  |  |  |  |  |  |  |  |  |  |  |  |  |
| 15x4  |  |  |  |  |  |  |  |  |  |  |  |  |  |  |  |  |  |  |  |  |  |  |  |  |  |
| PHF   |  |  |  |  |  |  |  |  |  |  |  |  |  |  |  |  |  |  |  |  |  |  |  |  |  |

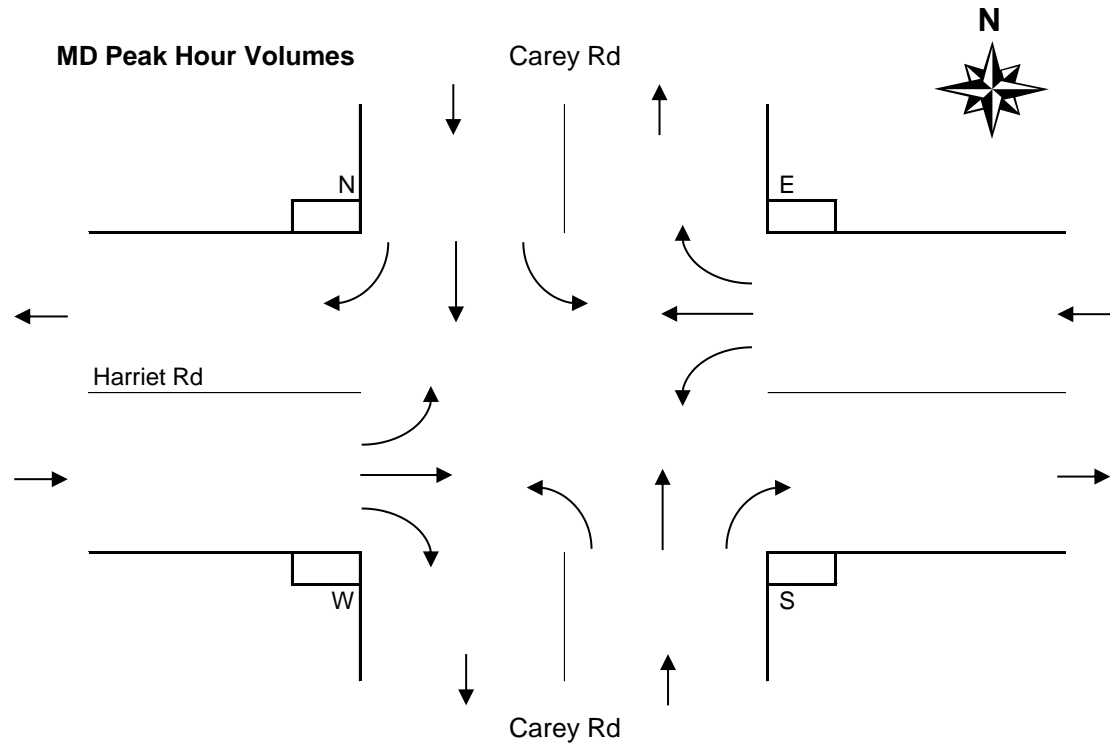

PM Peak Period  
Bikes

Carey Road @ Harriet Road  
Wednesday, April 3, 2019

| Time Period Begins | Carey Rd NORTH Approach |      |       |       | Carey Rd SOUTH Approach |      |       |       | Harriet Rd WEST Approach |      |       |       | Harriet Rd EAST Approach |      |       |       | Total Volume |      | Speed | Conflict |   |   |    |        |    |
|--------------------|-------------------------|------|-------|-------|-------------------------|------|-------|-------|--------------------------|------|-------|-------|--------------------------|------|-------|-------|--------------|------|-------|----------|---|---|----|--------|----|
|                    | Left                    | Thru | Right | Total | Left                    | Thru | Right | Total | Left                     | Thru | Right | Total | Left                     | Thru | Right | Total | 15-min       | Hour |       | N        | S | W | E  | 15 min | Hr |
|                    | 15:30                   | 0    | 0     | 0     | 0                       | 0    | 6     | 0     | 6                        | 0    | 0     | 0     | 0                        | 0    | 0     | 0     | 0            | 6    |       |          | 0 | 0 | 0  | 0      | 6  |
| 15:45              | 0                       | 1    | 0     | 1     | 0                       | 1    | 0     | 1     | 0                        | 0    | 0     | 0     | 0                        | 0    | 0     | 0     | 2            |      | 0     | 0        | 0 | 0 | 1  |        |    |
| 16:00              | 0                       | 1    | 0     | 1     | 0                       | 2    | 0     | 2     | 0                        | 0    | 0     | 0     | 0                        | 0    | 0     | 0     | 3            |      | 0     | 0        | 0 | 0 | 2  |        |    |
| 16:15              | 0                       | 1    | 0     | 1     | 0                       | 7    | 0     | 7     | 0                        | 0    | 0     | 0     | 0                        | 0    | 0     | 0     | 8            | 19*  | 0     | 0        | 0 | 0 | 7  | 16     |    |
| 16:30              | 0                       | 1    | 0     | 1     | 1                       | 8    | 0     | 9     | 0                        | 0    | 0     | 0     | 0                        | 0    | 0     | 0     | 10           | 23*  | 0     | 0        | 0 | 0 | 8  | 18     |    |
| 16:45              | 0                       | 4    | 0     | 4     | 0                       | 11   | 0     | 11    | 2                        | 0    | 0     | 2     | 0                        | 0    | 0     | 0     | 17           | 38+  | 0     | 0        | 0 | 0 | 13 | 30     |    |
| 17:00              | 0                       | 3    | 0     | 3     | 1                       | 5    | 0     | 6     | 0                        | 0    | 0     | 0     | 0                        | 0    | 0     | 0     | 9            | 44*  | 0     | 0        | 0 | 0 | 5  | 33     |    |
| 17:15              | 0                       | 0    | 0     | 0     | 1                       | 3    | 0     | 4     | 0                        | 0    | 0     | 0     | 0                        | 0    | 0     | 0     | 4            | 40   | 0     | 0        | 0 | 0 | 3  | 29     |    |
| 17:30              | 0                       | 1    | 0     | 1     | 0                       | 1    | 0     | 1     | 0                        | 0    | 0     | 0     | 0                        | 0    | 0     | 0     | 2            | 32   | 0     | 0        | 0 | 0 | 1  | 22     |    |
| 17:45              | 0                       | 1    | 0     | 1     | 1                       | 7    | 0     | 8     | 0                        | 0    | 0     | 0     | 0                        | 0    | 0     | 0     | 9            | 24   | 0     | 0        | 0 | 0 | 7  | 16     |    |
| 18:00              | 0                       | 3    | 0     | 3     | 0                       | 1    | 0     | 1     | 0                        | 0    | 0     | 0     | 0                        | 0    | 0     | 0     | 4            | 19   | 0     | 0        | 0 | 0 | 3  | 14     |    |
| 18:15              | 0                       | 0    | 0     | 0     | 0                       | 2    | 0     | 2     | 0                        | 0    | 0     | 0     | 0                        | 0    | 0     | 0     | 2            | 17   | 0     | 0        | 0 | 0 | 2  | 13     |    |
| n/a                |                         |      |       |       |                         |      |       |       |                          |      |       |       |                          |      |       |       |              |      |       |          |   |   |    |        |    |
| n/a                |                         |      |       |       |                         |      |       |       |                          |      |       |       |                          |      |       |       |              |      |       |          |   |   |    |        |    |
| n/a                |                         |      |       |       |                         |      |       |       |                          |      |       |       |                          |      |       |       |              |      |       |          |   |   |    |        |    |
| n/a                |                         |      |       |       |                         |      |       |       |                          |      |       |       |                          |      |       |       |              |      |       |          |   |   |    |        |    |
| n/a                |                         |      |       |       |                         |      |       |       |                          |      |       |       |                          |      |       |       |              |      |       |          |   |   |    |        |    |
| n/a                |                         |      |       |       |                         |      |       |       |                          |      |       |       |                          |      |       |       |              |      |       |          |   |   |    |        |    |
| n/a                |                         |      |       |       |                         |      |       |       |                          |      |       |       |                          |      |       |       |              |      |       |          |   |   |    |        |    |
| n/a                |                         |      |       |       |                         |      |       |       |                          |      |       |       |                          |      |       |       |              |      |       |          |   |   |    |        |    |
| n/a                |                         |      |       |       |                         |      |       |       |                          |      |       |       |                          |      |       |       |              |      |       |          |   |   |    |        |    |

|        |   |    |   |    |   |    |   |    |   |   |   |   |   |   |   |   |   |    |  |   |   |   |   |  |  |    |
|--------|---|----|---|----|---|----|---|----|---|---|---|---|---|---|---|---|---|----|--|---|---|---|---|--|--|----|
| Total  | 0 | 16 | 0 | 16 | 4 | 54 | 0 | 58 | 2 | 0 | 0 | 2 | 0 | 0 | 0 | 0 | 0 | 76 |  | 0 | 0 | 0 | 0 |  |  | 56 |
| Avg Hr | 0 | 5  | 0 | 5  | 1 | 18 | 0 | 19 | 1 | 0 | 0 | 1 | 0 | 0 | 0 | 0 | 0 | 25 |  | 0 | 0 | 0 | 0 |  |  |    |

Peak hour of the intersection

|       |     |      |     |      |      |      |     |      |      |     |     |      |     |     |     |     |      |  |     |     |     |     |  |  |      |
|-------|-----|------|-----|------|------|------|-----|------|------|-----|-----|------|-----|-----|-----|-----|------|--|-----|-----|-----|-----|--|--|------|
| Pk Hr | 0   | 9    | 0   | 9    | 2    | 31   | 0   | 33   | 2    | 0   | 0   | 2    | 0   | 0   | 0   | 0   | 44*  |  | 0   | 0   | 0   | 0   |  |  | 33   |
| 15x4  | 0   | 16   | 0   | 16   | 4    | 44   | 0   | 44   | 8    | 0   | 0   | 8    | 0   | 0   | 0   | 0   | 68*  |  | 0   | 0   | 0   | 0   |  |  | 52   |
| PHF   | n/a | 0.56 | n/a | 0.56 | 0.50 | 0.70 | n/a | 0.75 | 0.25 | n/a | n/a | 0.25 | n/a | n/a | n/a | n/a | 0.65 |  | n/a | n/a | n/a | n/a |  |  | 0.63 |

Peak hour of conflicting volumes for the intersection

|       |     |      |     |      |      |      |     |      |      |     |     |      |     |     |     |     |      |  |     |     |     |     |  |  |      |
|-------|-----|------|-----|------|------|------|-----|------|------|-----|-----|------|-----|-----|-----|-----|------|--|-----|-----|-----|-----|--|--|------|
| Pk Hr | 0   | 9    | 0   | 9    | 2    | 31   | 0   | 33   | 2    | 0   | 0   | 2    | 0   | 0   | 0   | 0   | 44*  |  | 0   | 0   | 0   | 0   |  |  | 33   |
| 15x4  | 0   | 16   | 0   | 16   | 4    | 44   | 0   | 44   | 8    | 0   | 0   | 8    | 0   | 0   | 0   | 0   | 68*  |  | 0   | 0   | 0   | 0   |  |  | 52   |
| PHF   | n/a | 0.56 | n/a | 0.56 | 0.50 | 0.70 | n/a | 0.75 | 0.25 | n/a | n/a | 0.25 | n/a | n/a | n/a | n/a | 0.65 |  | n/a | n/a | n/a | n/a |  |  | 0.63 |

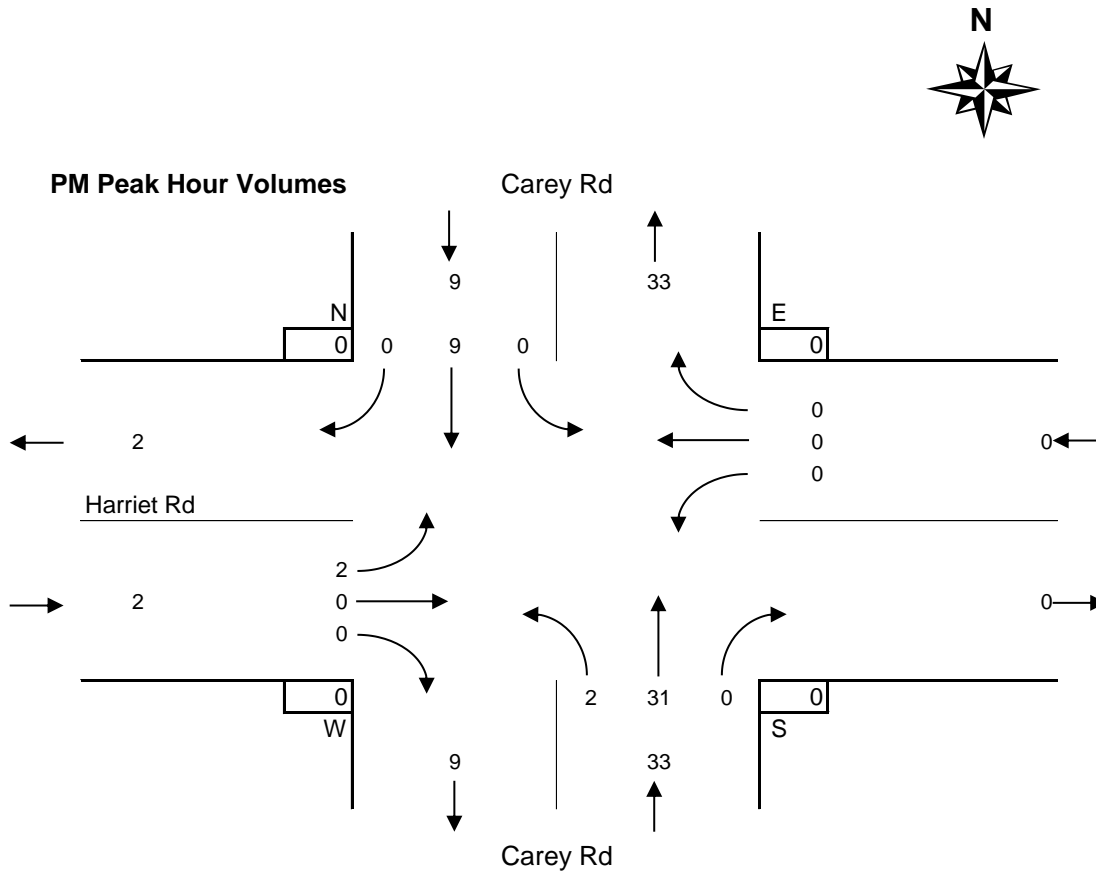

Entire Survey Period

5 Hours

|        | Carey Rd       |      |       |       | Carey Rd       |      |       |       | Harriet Rd    |      |       |       | EAST Approach |      |       |       | Total Volume |   |   |   |   |
|--------|----------------|------|-------|-------|----------------|------|-------|-------|---------------|------|-------|-------|---------------|------|-------|-------|--------------|---|---|---|---|
|        | NORTH Approach |      |       |       | SOUTH Approach |      |       |       | WEST Approach |      |       |       |               |      |       |       |              | N | S | W | E |
|        | Left           | Thru | Right | Total | Left           | Thru | Right | Total | Left          | Thru | Right | Total | Left          | Thru | Right | Total |              |   |   |   |   |
| Total  | 0              | 60   | 0     | 60    | 4              | 66   | 0     | 70    | 2             | 0    | 5     | 7     | 0             | 0    | 0     | 0     | 137          | 0 | 0 | 0 | 0 |
| Avg Hr | 0              | 12   | 0     | 12    | 1              | 13   | 0     | 14    | 0             | 0    | 1     | 1     | 0             | 0    | 0     | 0     | 27           | 0 | 0 | 0 | 0 |

AM Peak Period

2 Hours

|        | Carey Rd       |      |       |       | Carey Rd       |      |       |       | Harriet Rd    |      |       |       | EAST Approach |      |       |       | Total Volume |   |   |   |   |
|--------|----------------|------|-------|-------|----------------|------|-------|-------|---------------|------|-------|-------|---------------|------|-------|-------|--------------|---|---|---|---|
|        | NORTH Approach |      |       |       | SOUTH Approach |      |       |       | WEST Approach |      |       |       |               |      |       |       |              | N | S | W | E |
|        | Left           | Thru | Right | Total | Left           | Thru | Right | Total | Left          | Thru | Right | Total | Left          | Thru | Right | Total |              |   |   |   |   |
| Totals | 0              | 44   | 0     | 44    | 0              | 12   | 0     | 12    | 0             | 0    | 5     | 5     | 0             | 0    | 0     | 0     | 61           | 0 | 0 | 0 | 0 |
| Avg Hr | 0              | 22   | 0     | 22    | 0              | 6    | 0     | 6     | 0             | 0    | 3     | 3     | 0             | 0    | 0     | 0     | 31           | 0 | 0 | 0 | 0 |

MD Peak Period

Hours

|        | Carey Rd       |      |       |       | Carey Rd       |      |       |       | Harriet Rd    |      |       |       | EAST Approach |      |       |       | Total Volume |   |   |   |   |
|--------|----------------|------|-------|-------|----------------|------|-------|-------|---------------|------|-------|-------|---------------|------|-------|-------|--------------|---|---|---|---|
|        | NORTH Approach |      |       |       | SOUTH Approach |      |       |       | WEST Approach |      |       |       |               |      |       |       |              | N | S | W | E |
|        | Left           | Thru | Right | Total | Left           | Thru | Right | Total | Left          | Thru | Right | Total | Left          | Thru | Right | Total |              |   |   |   |   |
| Total  |                |      |       |       |                |      |       |       |               |      |       |       |               |      |       |       |              |   |   |   |   |
| Avg Hr |                |      |       |       |                |      |       |       |               |      |       |       |               |      |       |       |              |   |   |   |   |

PM Peak Period

3 Hours

|        | Carey Rd       |      |       |       | Carey Rd       |      |       |       | Harriet Rd    |      |       |       | EAST Approach |      |       |       | Total Volume |   |   |   |   |
|--------|----------------|------|-------|-------|----------------|------|-------|-------|---------------|------|-------|-------|---------------|------|-------|-------|--------------|---|---|---|---|
|        | NORTH Approach |      |       |       | SOUTH Approach |      |       |       | WEST Approach |      |       |       |               |      |       |       |              | N | S | W | E |
|        | Left           | Thru | Right | Total | Left           | Thru | Right | Total | Left          | Thru | Right | Total | Left          | Thru | Right | Total |              |   |   |   |   |
| Totals | 0              | 16   | 0     | 16    | 4              | 54   | 0     | 58    | 2             | 0    | 0     | 2     | 0             | 0    | 0     | 0     | 76           | 0 | 0 | 0 | 0 |
| Avg Hr | 0              | 5    | 0     | 5     | 1              | 18   | 0     | 19    | 1             | 0    | 0     | 1     | 0             | 0    | 0     | 0     | 25           | 0 | 0 | 0 | 0 |

